

**Section at Head
(Not to Scale)**

NOTES:

1. WINDOW/DOOR HEAD FLASHING IS REQUIRED WHERE THE VERTICAL DISTANCE BETWEEN THE TOP OF THE OPENING AND THE EAVE IS MORE THAN ONE-QUARTER OF THE HORIZONTAL OVERHANG
2. INSTALLATION MUST ALLOW POSITIVE OUTWARD SLOPE TO REMAIN AFTER BUILDING SETTLEMENT.
3. END-DAMS RECOMMENDED ON HEAD FLASHINGS TO PREVENT MOISTURE FROM ENTERING BEHIND STUCCO AT JAMB AREA. END-DAMS SHALL BE COMPATIBLE WITH THE HEAD FLASHING MATERIAL. THIS EXAMPLE IS AN END-DAM AS AN UPTURNED METAL EDGE.

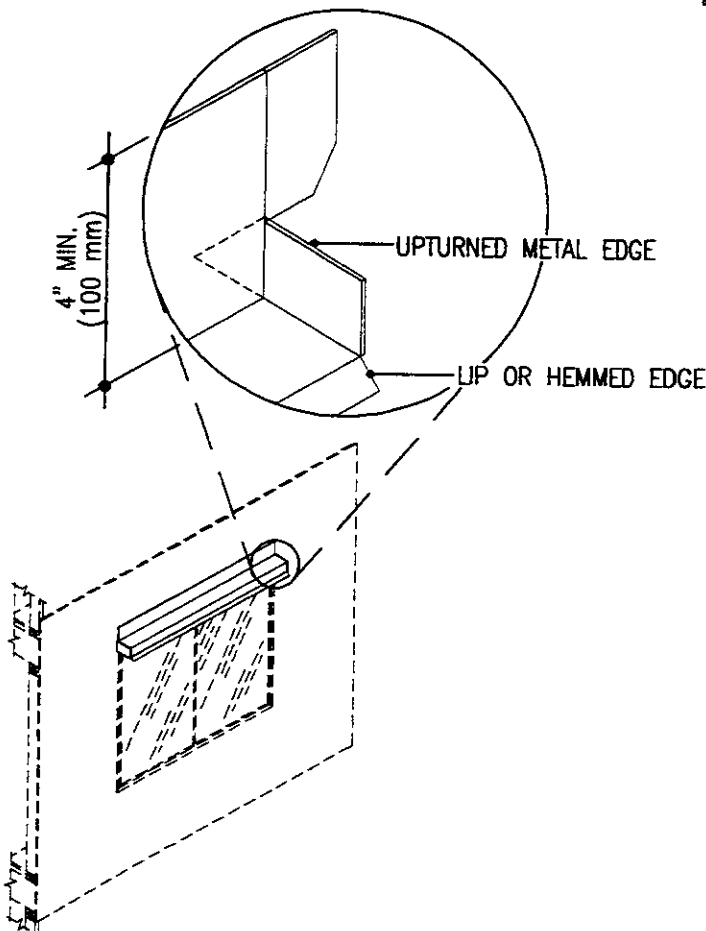

**End-Dam Axonometric
(Not to Scale)**

FWB9B -- Window Head Flashing Assembly